

## 1735N5C2B | 碳刷 Graphite Brush

应用领域：医疗、保健、汽车、机器人、工业自动化等精密驱动领域。

Applications: precision drives in medical equipment and devices, healthcare products, automotive, robotics, and industrial automation.

### 主要技术指标 | Characteristics

			01-125-12.0	02-90-24.0	
1	电压	Voltage	V	12.0	24.0
2	转子电阻	Rotor Resistance	$\Omega$	5.2	25.4
3	空载转速	No-load speed	rpm	12500	9000
4	空载电流	No-load current	mA	20	10
5	堵转转矩	Stall torque	mNm	20.8	23.4
6	堵转电流	Stall current	mA	2310	940
7	额定转矩	Nominal torque	mNm	5.0	5.0
8	额定转速	Nominal speed	rpm	9500	7080
9	额定电流	Nominal current	mA	570	210
10	最大输出功率	Max. output power	W	6.8	5.5
11	最大效率	Max. efficiency	%	82	81
12	反电势常数	Back-EMF constant	mV/rpm	1.0	2.6
13	转矩常数	Torque constant	mNm/A	9.1	25.2
14	转速 / 转矩斜率	Speed/torque gradient	rpm/mNm	600	380
15	转子惯量	Rotor inertia	gcm <sup>2</sup>	0.95	0.95
16	重量	Weight	g	34	34
17	热阻 (机壳 - 环境)	Thermal resistance housing-ambient	K/W		25.7
18	热阻 (线圈 - 机壳)	Thermal resistance winding-housing	K/W		30.4
19	热时常数 (电机)	Thermal time constant motor	s		245
20	热时常数 (线圈)	Thermal time constant winding	s		232
21	工作温度范围	Operating temperature range	°C		-20~+85
22	绕组耐温等级	Thermal class of winding	°C		130
23	轴向间隙	Axial play	mm		0.01~0.15
24	径向间隙	Radial play	mm		0.025
25	动态轴向载荷	Axial load dynamic	N		2.2
26	静态轴向载荷	Axial load static	N		30
27	径向载荷 (距安装面 3mm)	Radial load at 3 mm from mounting face	N		8
28	极对数	No. of pole pairs			1
29	轴承	Bearings			2 枚滚动轴承/2 ball bearings
30	换向结构	Commutator			贵金属 5 相/metal 5 segments
31	防护等级	Protection class			IP 30

★可选参数 Options: 导线长度 Lead wires length 轴长 Shaft length 性能 Special coils

齿轮箱 Gearheads 编码器 Encoder

### 外观图 | Outline Drawing

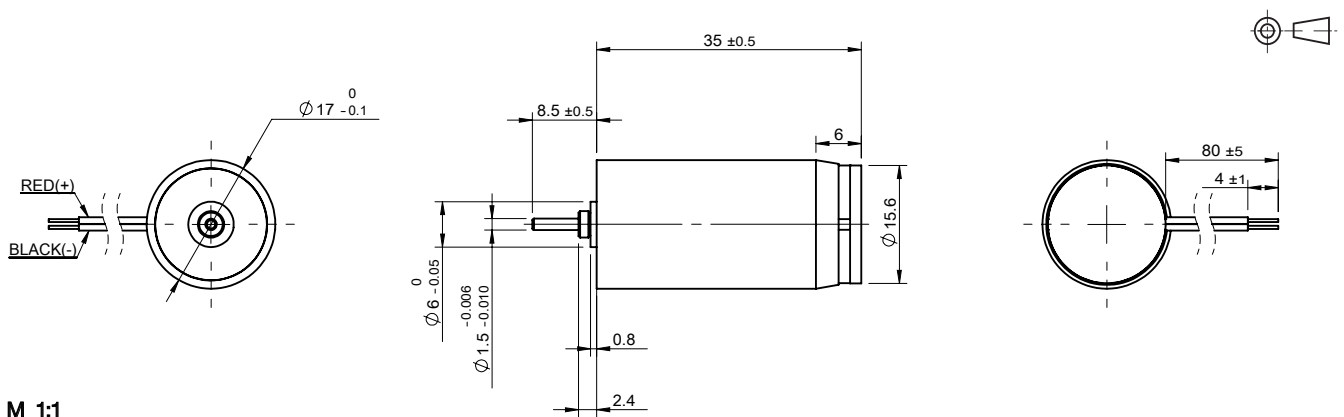

M 1:1