

L8.523N5M $\varnothing 8.5\text{mm} \times 23.2\text{mm}$, 贵金属电刷 Precious Metal Brushes

应用领域: 微型无人机、智能电玩、小家电产品等领域。

Applications: mini UAV's, remote control hobby products, small household appliances, etc.

12-344-3.7 14-367-3.0 31-460-3.0

电机参数 / Motor Data

电机参数 / Motor Data	电压	V	3.0	3.0	3.0
1 电压	Voltage	V	3.0	3.0	3.0
2 端电阻	Terminal resistance	Ω	0.47	0.45	0.36
3 空载转速	No-load speed	rpm	34400	36700	46000
4 空载电流	No-load current	mA	140	160	200
5 堵转转矩	Stall torque	mNm	5.1	5	4.9
6 堵转电流	Stall current	mA	6380	6670	8330
7 负载转矩	Load torque	mNm	1	1	1
8 负载转速	Load speed	rpm	27640	29300	36700
9 负载电流	Load current	mA	1370	1470	1840
10 最大输出功率	Max. output power	W	4.58	4.77	5.96
11 最大效率	Max. efficiency	%	72.7	71.5	71.5
12 反电势常数	Back-EMF constant	mV/rpm	0.09	0.08	0.06
13 转矩常数	Torque constant	mNm/A	0.81	0.76	0.61
14 转速 / 转矩斜率	Speed/torque gradient	rpm/mNm	6765	7404	9304
15 转子惯量	Rotor inertia	gcm^2	0.09	0.09	0.09
16 重量	Weight	g	5.6	5.6	5.7
17 工作温度范围	Operating temperature range	$^{\circ}\text{C}$	-20~+120		

特性曲线 / Characteristics Curve

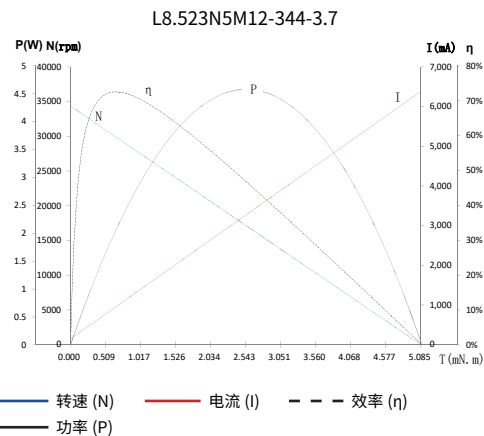

仅供参考, 详细了解请以产品规格书为准。
For reference only, please refer to the product specification.

可选配置 / Options

齿轮箱: 行星齿轮

Gearbox: planetary gearbox

齿轮组主要技术指标详见第 158 页

the main technical indicators of the gear group are detailed on page 158

性能 Special coils: 连续运行范围内可定制 customizable in continuous operation range

法兰 Flange: 标准前后法兰 standard front and rear flanges / 定制法兰 custom flanges

轴 Shaft: 长度 length / 异形 shape

电气连接 Electrical connection: 端子或导线 connector or wire / 导线长度 lead wires length

外观图 / Outline Drawing

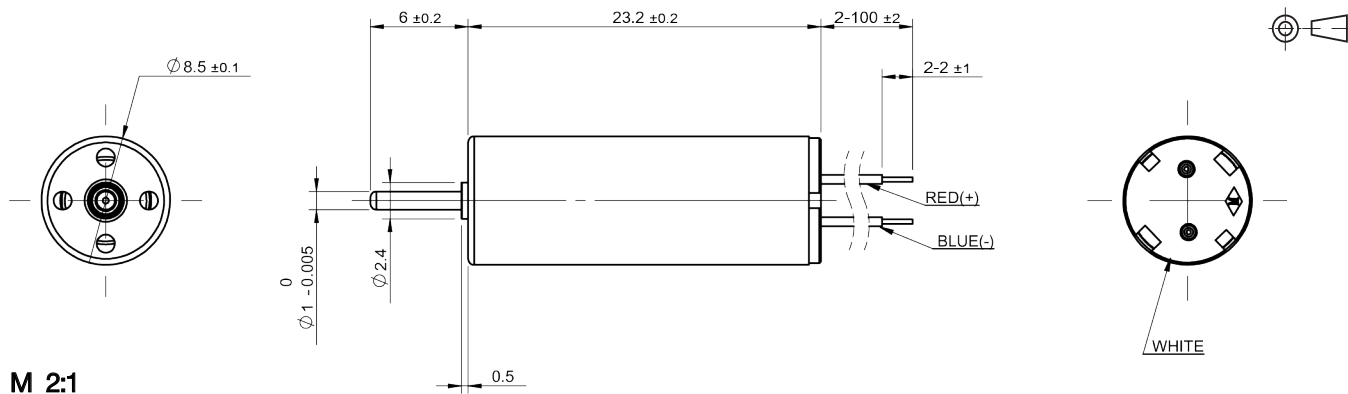

规格如有变更, 恕不另行通知。Specification subject to change without notice.

www.constarmotor.com

精密直流空心杯电机
PRECISION DC CORELESS MOTOR

无刷电机
BRUSHLESS DC MOTOR

驱动器
CONTROLLER

精密齿轮减速电机
PRECISION GEAR MOTOR

精密伺服电机
PRECISION SERVO MOTOR

直流空心杯电机
DC CORELESS MOTOR

直流铁芯电机
DC CORE MOTOR

声波振动电机
SONIC MOTOR

全球营销网络
GLOBAL MARKETING NETWORK